



Protection Solutions for a Safer World

Ballistic Shades and Door Shields

Product Introduction and Training



Product Overview

Problems with Traditional Solutions

- Customers get surprised at how complicated existing solutions are
 - Does not maintain comfortable, casual aesthetics
- Bullet-resistant doors:
 - Heavy (3-15lbs/ft²)
 - Finger and hand-crushing liability
 - Construction project to add them
 - \$4000-\$8000 for just the door
- Bullet-resistant windows:
 - HEAVY! (10-20lbs/ft²)
 - Window can no longer be used as an exit
 - Glass is so thick it distorts the view
 - Major construction project to add them if the wall is not designed for the weight
 - Over \$140/ft² for just the material



The perception that
“bulletproofing” is easy...



Versus the reality of
“bullet resistance”

Ballistic Fabric Compared to Traditional Options

- Provides a safe environment without negatively impacting the aesthetics of the space
- Kevlar is significantly lighter
 - Glass is up to 20x heavier
 - Plastic is 7x heavier
 - Fiberglass is 4x heavier
 - Steel is 5x heavier
- Flexible, can conform to any shape
- Installation time is minutes versus hours/days
- No need for structural reinforcement or permits to install
- Easy to conceal
- Allows removable/temporary/portable protection

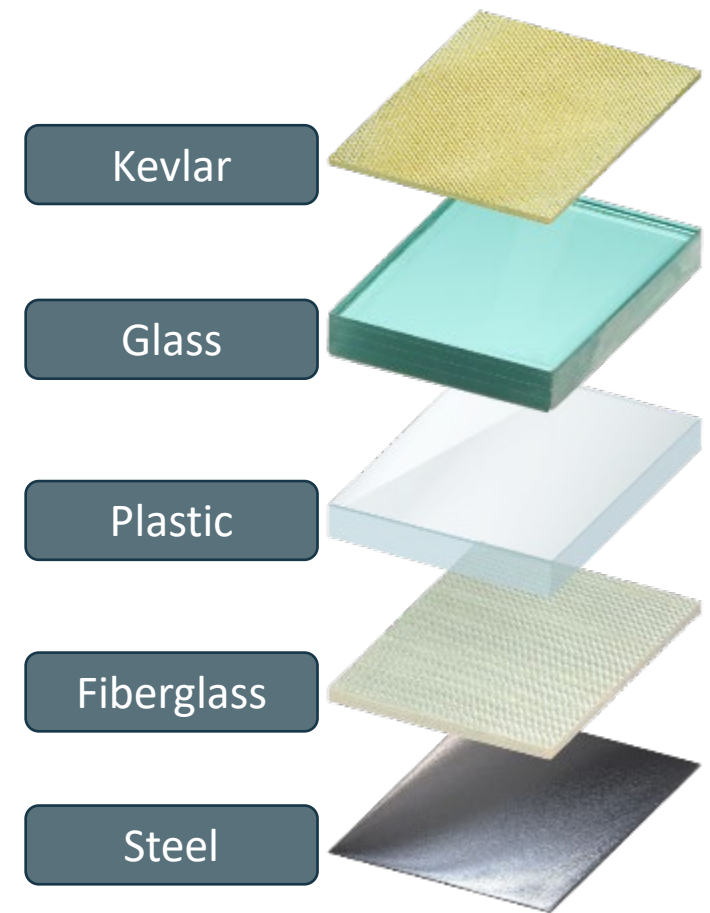

Security Films

- Misperception in the marketplace that “security films” are bullet-resistant
 - Films stop intruders – not bullets
- Some testing is being misrepresented
 - Tests done with non-standard glass
 - Tests done with non-standard ammunition
 - Test don’t advertise that the window frame was reinforced
 - Tests were not with a “film” but rather a plastic laminate
- Some dealers allow the misunderstanding to go unchecked to get the sale



Ballistics Barrier Products

A practical solution: First ever all-fabric ballistic solution for doors and windows



Attractive



Easy to buy



Easy to install



Fraction of the weight



Modest cost (with installation + shipping)



Effective protection



Inherently flame resistant



Made in the USA (Berry Amendment compliant)



Basic Construction

1. Kevlar
2. Polyester cover fabric
3. Elastomer

- Conventional bullet-resistant fabric relies on fibers to have the tensile strength to withstand bullet penetration on their own
- BBP adds a mechanical system to dissipate the impact energy of the bullet

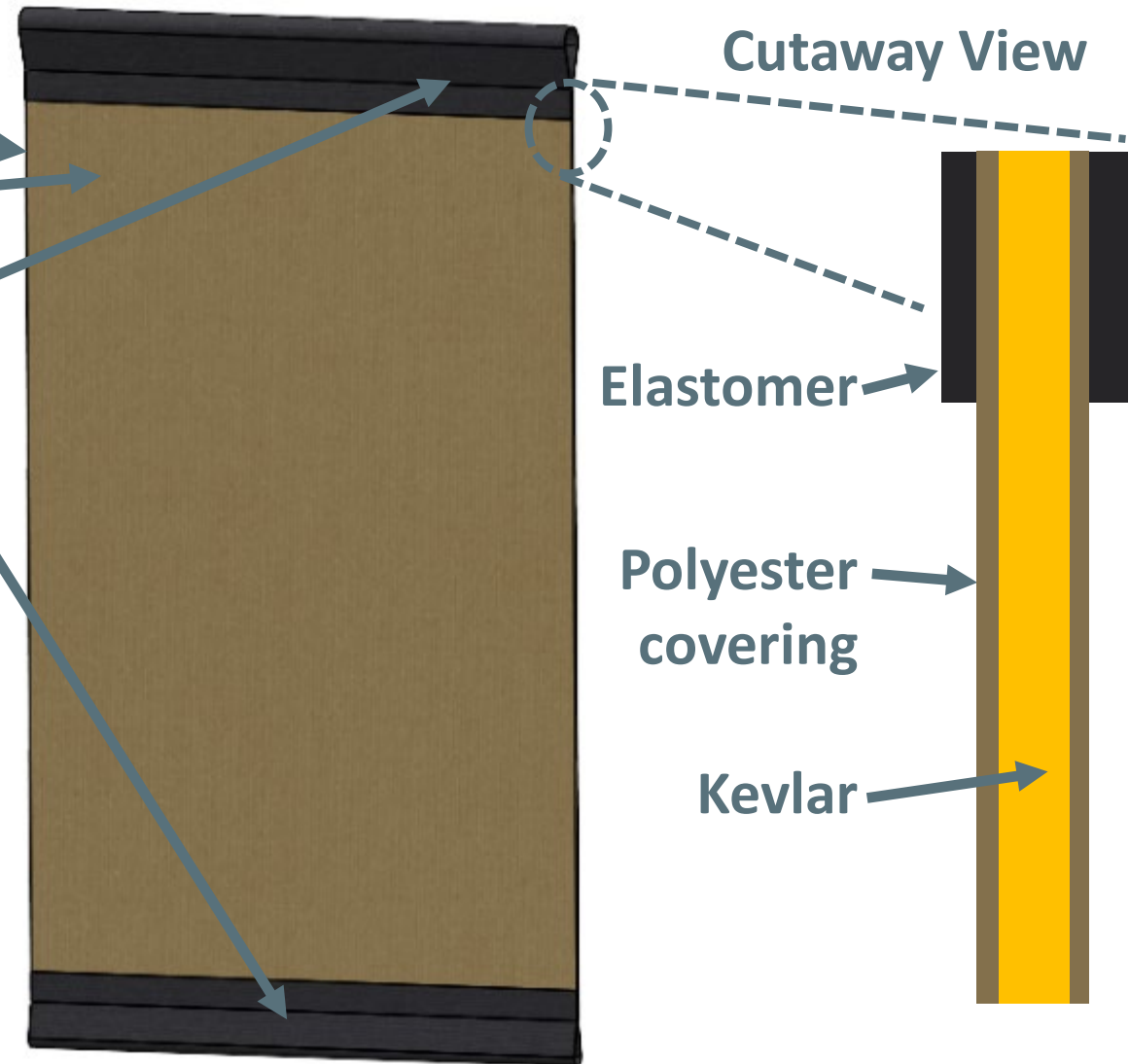

Fabric Components

- Kevlar (para-aramid) fiber core
 - Thickness depends on certification level
- Four standard solid colors offered (lower cost and shorter lead time)
- Customization available:
 1. Cover fabric can be dyed any shade
 2. Printing process can be used to make custom patterns
 3. Existing fabrics can be laminated to the top
 - Limitation to this process if it increases the stiffness of the roll too much

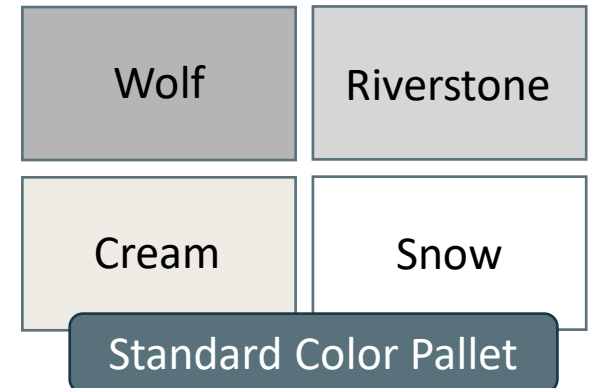
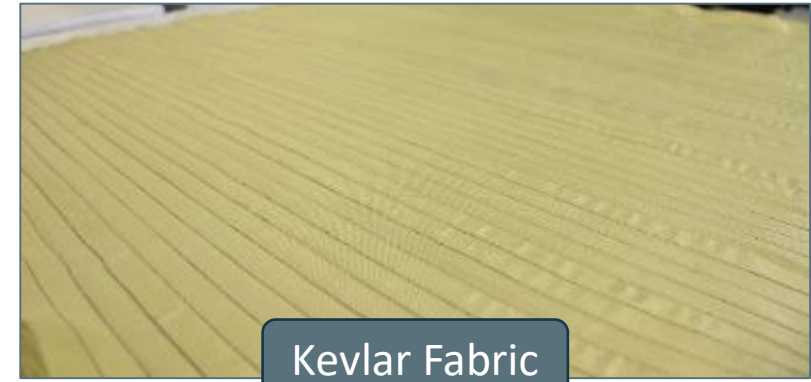

Windows

- Always a custom design due to the amount of variation possible
- Largest single window: 106" w x 103" h

Three product offerings:

1. Locking Hem Bar Shade

- Locking mechanism sits below the window, engages the hem bar when it is down
- Must be manually released from locks to retract the shade

2. Cable Guided Shade

- Hem bar is guided to the bottom along cables, freely retracts when activated

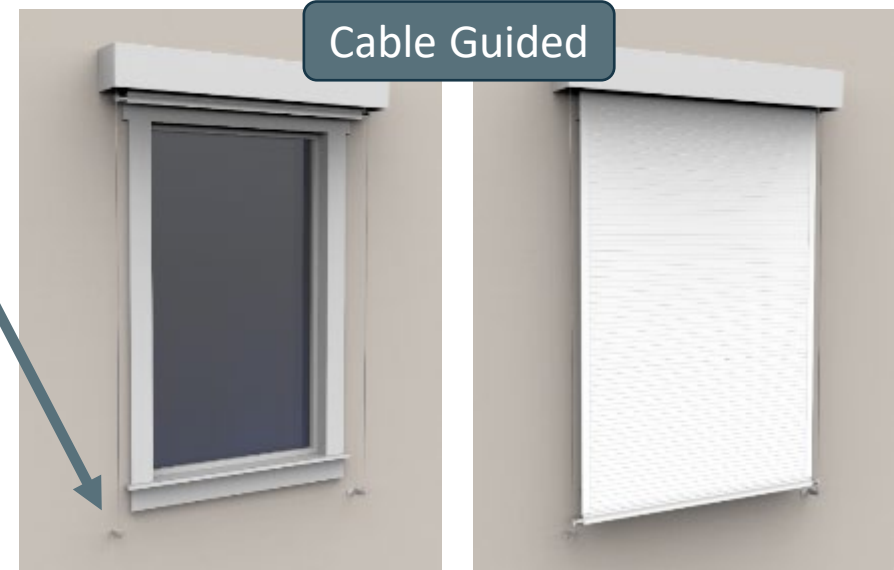
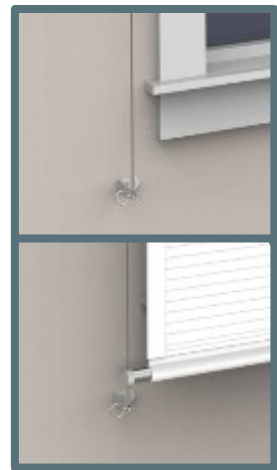

Windows

3. Pull Curtain

- No mechanism to retain the bottom
 - Recommended to be at least 12 sq ft
 - Has “memory”, needs a tie-back or sash
 - Curtains are manual pull to open/close
 - Only offered up to Level 2 (Level 3 is too stiff to move)
- All shades can be motorized with multiple activation options:
 - Wireless remote
 - Wall switch
 - Wire to an alarm system to smart home controls (local Somfy dealer will provide support for this)



Door Shields

- Standard size available for:
 - 30", 36" wide doors
 - 80", 84", and 96" heights
- Custom sizing available
- Two product offerings:
 - 1. Roll-Up Door Cover**
 - Hem bar is guided by cables
 - 2. Fixed Panel**
 - Industrial, school, or public buildings
 - Permanently mounted to the door
 - Provision for covering windows

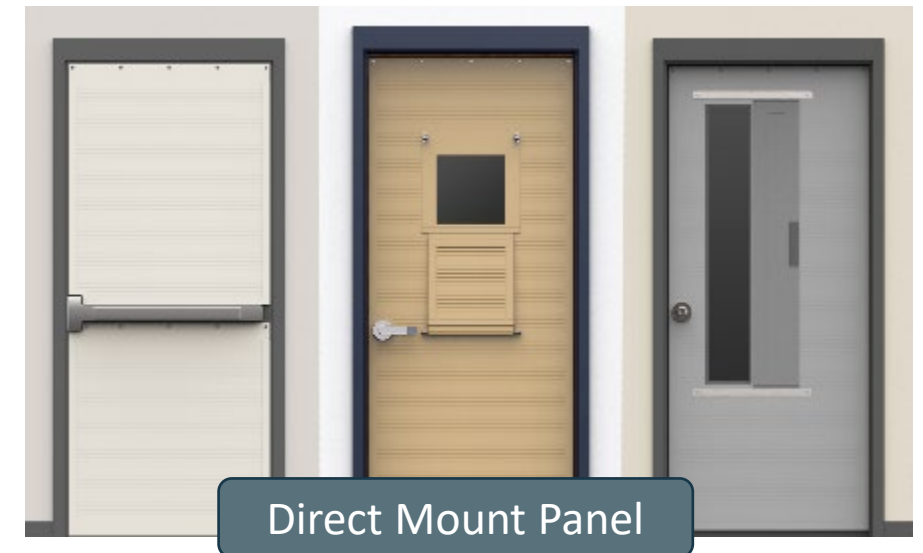
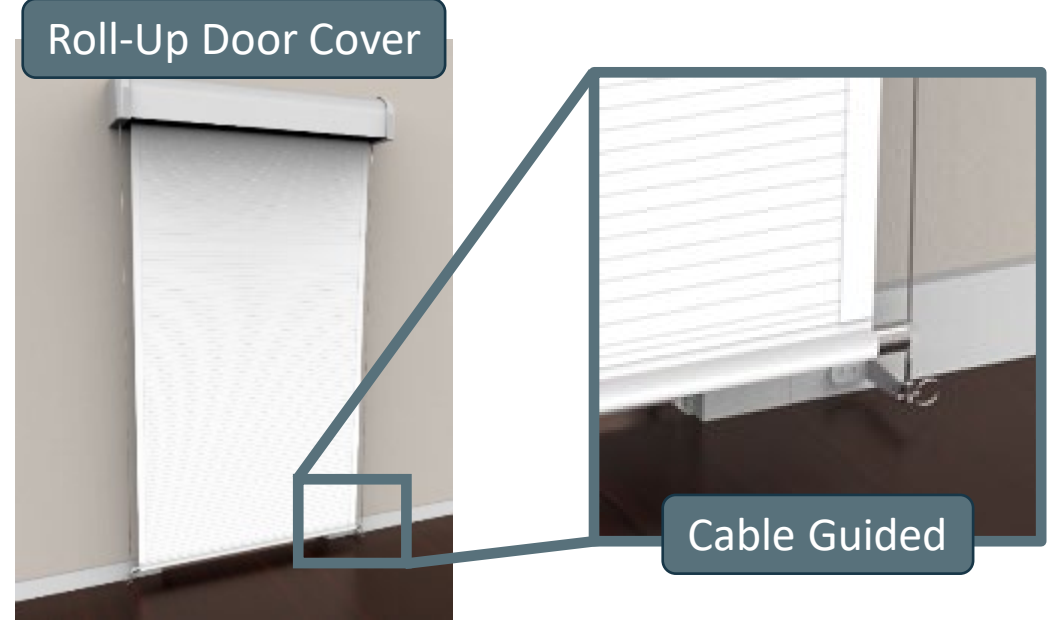

Barriers

- Hallway segregation
- Blast debris protection
 - Not certified protection against shock waves
- Shrouding test equipment
- With or without feature to roll-up/down
- Large format available
 - Up to 106" wide
 - Up to 103" height
- Frame and mechanicals will be custom designed to fit the request



Stock Bullet/Blast Debris Blanket

- 48x96
 - Mounts for portrait and landscape configurations
- 96x96
- UL Level 3 protection
 - Same level of protection against blast debris that the US military uses in personal body armor
- Two color options:
 - US Military OCP pattern
 - Civilian Gray
- Customization is possible, but lead time and cost increase



Ballistic Standards

Ballistic Standards 101

- UL
 - The UL752 rating system is generally considered the “gold standard” of bullet-resistant materials ratings for protective barriers and physical security.
 - Not only is it the oldest and most often updated standard (first codified in 1937 and now in its 11th edition), but it is also the most nuanced.
- ASTM
 - The standard most salient to ballistic barriers for structures would be ASTM F1233.
 - This standard primarily focuses on forced entry.
 - It determines the “class” of resistance to forced entry through impact testing with blunt and sharp tools, thermal stress (torch and extinguisher), and exposure to the chemicals gasoline and acetone. The test is progressive, repeated in particular sequences until failure.
 - Importantly, ASTM F1233 defines two levels of failure. The first level of failure is the creation of a hole allowing the passage of a 1/8" diameter object (so-called “passage of contraband”). The second is a breach allowing passage of a 5" by 8" by 8" rectangular object (i.e., “body passage”).
- NIJ
 - The NIJ was founded in 1968 and significantly expanded in 1979.
 - Their mission is to “encourage research and development to improve the criminal justice system and to disseminate the results to Federal, State, and local agencies.”
 - NIJ took the lead in developing standards and testing soft body armor (i.e., “bulletproof vests”) for law enforcement back in the 1960s and 1970s.
 - They continue to administer a program to test commercially available body armor for compliance with their minimum performance standards.

Why Experts Prefer UL752

NIJ: Someone who has come out of a law enforcement or military background that wore body armor will be familiar with NIJ standards. It's a name they trust.

ASTM: A glazier or a windows materials manufacturer might be more familiar with this standard.

UL: Builders are most accustomed to UL752 and other UL standards.

- What's most important is that you understand what you're getting.
- Regardless of which standard someone is using, a third-party lab has independently tested and confirmed that the item would stop:
 - A specific number of bullets
 - Specific calibers
 - At a given distance
- If a company can't show you that certification, then what they're selling isn't reliable.

UL Certification

- Any UL certified product is searchable in the public UL database



CERTIFICATE OF COMPLIANCE

Certificate Number BP21350
 Report Reference BP21350-2022-03-31
 Date 2022-August-24

Issued to: Ballistic Barrier Products Inc
 108 Ashe St
 Johnson City TN, 37604 US

This is to certify that representative samples of BULLET-RESISTING DEVICES, MISCELLANEOUS
 See Addendum Page for Product Designation(s).

Have been evaluated by UL in accordance with the Standard(s) indicated on this Certificate.

Standard(s) for Safety: UL752, Bullet Resisting Equipment
Additional Information: See the UL Online Certifications Directory at <https://iq.ulprospector.com> for additional information

This Certificate of Compliance indicates that representative samples of the product described in the certification report have met the requirements for UL certification. It does not provide authorization to apply the UL Mark. Only the Authorization Page that references the Follow-Up Services Procedure for ongoing surveillance provides authorization to apply the UL Mark.

Only those products bearing the UL Mark should be considered as being UL Certified and covered under UL's Follow-Up Services.

Look for the UL Certification Mark on the product.

UL LLC
 Any information and documentation involving UL Mark services are provided on behalf of UL LLC (UL) or any authorized licensee of UL. For questions, please contact a local UL Customer Service Representative at ul@ulprospector.com

CERTIFICATE OF COMPLIANCE

Certificate Number BP21350
 Report Reference BP21350-2022-03-31
 Date 2022-August-24

This is to certify that representative samples of the product as specified on this certificate were tested according to the current UL requirements

Bullet-Resisting Devices, Ballistic Barrier Screen Assembly, Model BBP752-L3

Device	Level 3
Ballistic Barrier Screen Assembly	BBP752-L3













Device	Level 2
Ballistic Barrier Screen Assembly	BBP752-L2













UL LLC
 Any information and documentation involving UL Mark services are provided on behalf of UL LLC (UL) or any authorized licensee of UL. For questions, please contact a local UL Customer Service Representative at ul@ulprospector.com

UL 752 Certification and Compliance

Certified

Compliant

 UL 752 Requirements					
UL* Level	Threat	Number of Shots	Grain	Max. Velocity (fps)	
1	9mm Handgun 	3	124	1293	
2	.357 Magnum Handgun 	3	158	1375	
3	.44 Magnum Handgun 	3	240	1485	
4	.30 Caliber Rifle 	1	180	2794	
5	7.62 mm Rifle, Single Shot 	1	150	3025	
6	9mm Higher Velocity 	5	124	1540	
7	5.56 mm Rifle 	5	55	3388	
8	7.62 mm Rifle, Multi Shot 	5	150	3025	
9	.30 Caliber Rifle Armor Piercing 	1	166	2987	
10	.50 Caliber Rifle 	1	709.5	3091	
Shotgun	12 ga, Rifled Slug 	3	437	1744	
	12 ga, 00 Buckshot 	3	650	1320	
Test range distance, 15 ft					
*UL 752, 11th ed.					
**NIJ 0108.01 Ballistic Resistant Materials					

 UL 752 Requirements					
UL* Level	Threat	Number of Shots	Grain	Max. Velocity (fps)	
1	9mm Handgun 	3	124	1293	
2	.357 Magnum Handgun 	3	158	1375	
3	.44 Magnum Handgun 	3	240	1485	
4	.30 Caliber Rifle 	1	180	2794	
5	7.62 mm Rifle, Single Shot 	1	150	3025	
6	9mm Higher Velocity 	5	124	1540	
7	5.56 mm Rifle 	5	55	3388	
8	7.62 mm Rifle, Multi Shot 	5	150	3025	
9	.30 Caliber Rifle Armor Piercing 	1	166	2987	
10	.50 Caliber Rifle 	1	709.5	3091	
Shotgun	12 ga, Rifled Slug 	3	437	1744	
	12 ga, 00 Buckshot 	3	650	1320	
Test range distance, 15 ft					
*UL 752, 11th ed.					
**NIJ 0108.01 Ballistic Resistant Materials					

Our Safety Claim (what you can/can't say)

- **Don't say**
 - "Bulletproof" – nothing is perfectly bulletproof
 - ALL handguns
- **Do say**
 - Bullet-resistant
 - Certified to UL 752 Level 3 and Level 2
 - Not just compliance tested, but certified by an independent lab with expertise in the subject matter
 - Level 3 is the highest level that UL has for handgun testing
 - Passing Level 3 means
 - The product is sufficient to protect against the most common pistol calibers
 - This includes commercially available and typical rounds for .38 Special, .357 Magnum, 9mm, .45, .40, 10mm, and .44 Magnum
- **Don't push:** the customer has to make 100% of the decisions without coercion, without scare tactics, without debate

SECURITY



Level 3
BP21350

LISTED

SECURITY



Level 2
BP21350

LISTED

Our Safety Claim

- BBP also maintains the certification listing: requires quarterly audits from UL to confirm the construction has not changed
- Why not rifle certified?
 - Rifle certification in a pure fabric solution is impractical
 - Requires rigid materials due to the velocity and pointed slug's ability to pierce Kevlar fabric
 - For this reason, rifle-rated body armor always has ceramic, polymer, or metal plates in front of the fabric
 - To blunt the nose of the rifle round
 - Rifle rating is only in the area of the plates

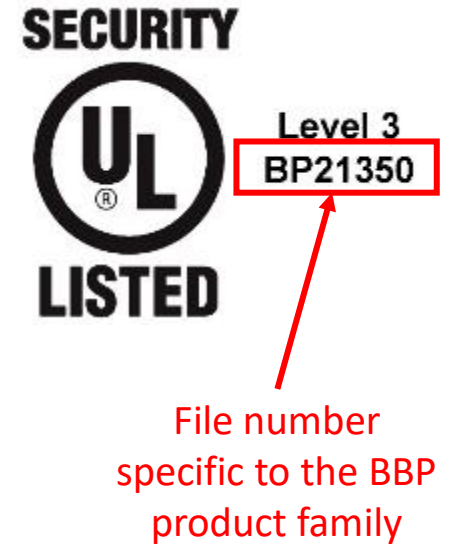

Testing Beyond UL Level 2 and 3

- Not certified but informally tested to be compliant:
 - UL Level 1
 - UL Shotgun, buckshot only
 - UL Level 6 sub-machine gun
 - 200 rounds of full-auto 9mm and .45 machine gun fire without penetration across a 4x5 shade
 - Concentrated fire in one tight zone WILL eventually breach (typically > 30 rounds)
- NIJ standard?
 - Compliant with some of the categories, but not certified
- V50 testing applied
 - Mil-Std 662 for V50 testing strategy was used (versus V0 testing)
 - This means the product is designed to have a significant safety margin over simply meeting the certification levels
- Fire resistance to NFPA 701
 - Flame resistant is the correct term (not flame retardant): inherently non-flammable, won't support combustion

Ballistic Barrier Products		UL 752 Requirements				
UL* Level	NIJ** Equivalent	Threat	Number of Shots	Grain	Max. Velocity (fps)	
1	II	9mm Handgun 	3	124	1293	
2		.357 Magnum Handgun 	3	158	1375	
3	IIIA	.44 Magnum Handgun 	3	240	1485	
4		.30 Caliber Rifle 	1	180	2794	
5		7.62 mm Rifle, Single Shot 	1	150	3025	
6	IIIA	9mm Higher Velocity 	5	124	1540	
7		5.56 mm Rifle 	5	55	3388	
8	III	7.62 mm Rifle, Multi Shot 	5	150	3025	
9	IV	.30 Caliber Rifle Armor Piercing 	1	166	2987	
10		.50 Caliber Rifle 	1	709.5	3091	
Shotgun		12 ga, Rifled Slug 	3	437	1744	
		12 ga, 00 Buckshot	3	650	1320	
Test range distance, 15 ft						
*UL 752, 11th ed.						
**NIJ 0108.01 Ballistic Resistant Materials						

Measurements for Quoting

BBP Order Forms

- HARD** requirement to use the BBP measurement forms:

- Window Shades
- Door Covers
- Fixed Door Shields
- Curtains

- No orders accepted without a measurement form

Roll-Up Window Shades and Door Shields

1. Fill out sections 1-10 completely (inches assumed, if metric, indicate as such)
 2. Scan and return to sales@ballisticbarrier.com
 3. For existing construction, you must include a photo of each door, including 12 inches in each direction around it.
 For any new fabric or construction option not listed here, contact sales@ballisticbarrier.com directly with your request.

Measurements

Item	20x28	20x30	20x34	20x44	20x46	Custom
Door (Shade only)						
Window/Curtain Door shade						
Window/Curtain Door height	See Figure 1					
Edge of obstruction frame to floor to rolling length (in)	Left	Right	See Figure 2			
Stool material	Wood	Plastic	Concrete			
Door/window trim width	If width varies, describe trim width on all four sides in section 10					
Size limitations	Maximum window shade roll length is 130" (Choose the width or the length not to exceed 130" for one roll)					

Check Size By Detached (See Figure 3)

Remove the obstruction frame At least 12" clearance If no, then please photograph the obstruction and provide the distance to its edge from the roller frame edge in section 10

To the left and right of the frame At least 12" clearance, each side

Below the frame (window only) At least 2" clearance

Door only, shade fabric protrude past the surrounding wall to less than 2" If no, note measurement in section 10

Threat Level (select one)

UL 752 Level 1 Up to 4H Magnum protection

UL 752 Level 2 Up to 3G Magnum and 5mm protection

Mounting (select one)

Wall mount

Ceiling mount

Color (select one)

Manual (left side) Full cover, right side Manual (right side must be >30 sq ft)

Power (left side) Power cord left side Full cover, right side Power cord right side With exposed wires (UL, N, G)

Roller (select one)

None

Roller sheet metal Color: Hologram, Winter, Snow (see below)

Fabric covered Style: Choose to match cover fabric or custom

Item Size Attention (select one)

None Recommended overall size >12 sq ft

Loading from bar Windows only

Code pulled Windows or doors

Cover Fabric Type (select one)

Standard polyester

Custom fabric (describe)

Cover Fabric Color (select one)

Standard colors (select one)

Custom color (describe)

Special Considerations (Name blank if none)

Curtains

1. Fill out sections 1-10 completely (inches assumed, if metric, indicate as such)
 2. Scan and return to sales@ballisticbarrier.com
 3. For existing construction, you must include a photo of each window/door, including 12 inches in each direction around it.
 For any new fabric or construction option not listed here, contact sales@ballisticbarrier.com directly with your request.

Measurements

Item	20x28	20x30	20x34	20x44	20x46	Custom
Window width (inches)						
Window height (inches)	See Figure 1					
Window, edge of frame to stud (inches)	Left	Right	See Figure 2			
Window trim width	If width varies, describe trim width on all four sides in section 8					
Size Limitations	Roller width or height cannot exceed 130" roll total width					

Windowing Requirements Checklist (See Figure 3)

Yes/No

Above the window frame At least 12" clearance If no, then please photograph the obstruction and provide the distance to its edge from the roller frame edge in section 10

Below the window frame At least 4" clearance

To the left and right of the frame At least 12" clearance, each side

2% of the total width is 0?"

Threat Level (select one)

Up to 4H Magnum protection

Up to 3G Magnum and 5mm protection

Mounting (select one)

Acquisition style (allows material consumption by 20-40%)

Rolling diameter

Must be less than 6" between supports and roll diameter must be at least 1/2"

Power cord right side

Roller

Standard, Water proofing plug

Concrete wall sections (request wires 2, N, G)

Color (select one)

Standard colors (select one)

Custom color (describe)

Special Considerations (Name blank if none)

Fixed Panel Door Shields

1. Fill out sections 1-10 completely (inches assumed, if metric, indicate as such)
 2. Scan and return to sales@ballisticbarrier.com
 3. For existing construction, you must include a photo of each door, including 12 inches in each direction around it.
 For any new fabric or construction option not listed here, contact sales@ballisticbarrier.com directly with your request.

Measurements

Item	20x28	20x30	20x34	20x44	20x46	Custom
Door width (inches)						
Door height (inches)	See Figure 1					
Door edge to stud (inches)	Left	Right	See Figure 2			
Door trim width	If width varies, describe trim width on all four sides in section 8					

Threat Level (select one)

UL 752 Level 1 Up to 4H Magnum protection

UL 752 Level 2 Up to 3G Magnum and 5mm protection

Window in Door (select one)

No window

Window (See Figure 3) Width: _____ Height: _____ To door top (in) _____ To door edge (in) _____

Window cover solution (See Figure 3) Nothing, same window; Create a matching hole in the header; Flip up cover; Sliding cover

Door Break/Frame Rein (select all that apply)

Full bar Heads and mold needed, if not suitable, BBP will provide measurement guidance

Door head (or vent) Backset: [] 2 1/8" [] 2 3/4" (See Figure 1)

Door sill Distance from center of deadbolt to center of lock: _____

Door Sill (select one)

Left side of door

Right side of door

Door Sill Material (select one)

Door cover wood Select one (see below) If no, then please photograph the obstruction and provide the distance to it from the nearest drilling through (see below) Header edge is inches below

Roller cover wood

Header cover metal

Door metal

Bottom Style (select one)

Free hanging Door shield will be free to move as door opens and closes

None required Flow of water will require the bottom of the roller, being it in place

Cover Fabric Type (select one)

Standard polyester

Custom fabric (describe)

Cover Fabric Color (select one)

Standard colors (select one)

Custom color (describe)

Special Considerations (Name blank if none)

3 Keys to a Successful Order

- 1) **Correctly define the “Protection Zone”** – what area does the customer wants covered by Kevlar?
 - If these numbers are wrong, the Kevlar usually cannot be salvaged.
- 2) **Identify all obstacles that will be in the way of the shade/cover from going up and down.**
 - This may require consultation with BBP, but the installer owns this problem.
 - **ALWAYS** send a photo of the entire area around the window/door.
- 3) **Figure out where the brackets will mount.**
 - This may require consultation with BBP, but the installer owns this problem.

Do not leave the site without all three keys being resolved or you may be coming back.

Window Measurements

Measure the “Protection Zone” width and height

- Width goes from side to side and is ALWAYS listed first when next to the height number.
- Height (NOT called length) is from top to bottom.
- The window Protection Zone is usually more than the glass as many windows will have a vinyl frame that is just as weak as the glass.

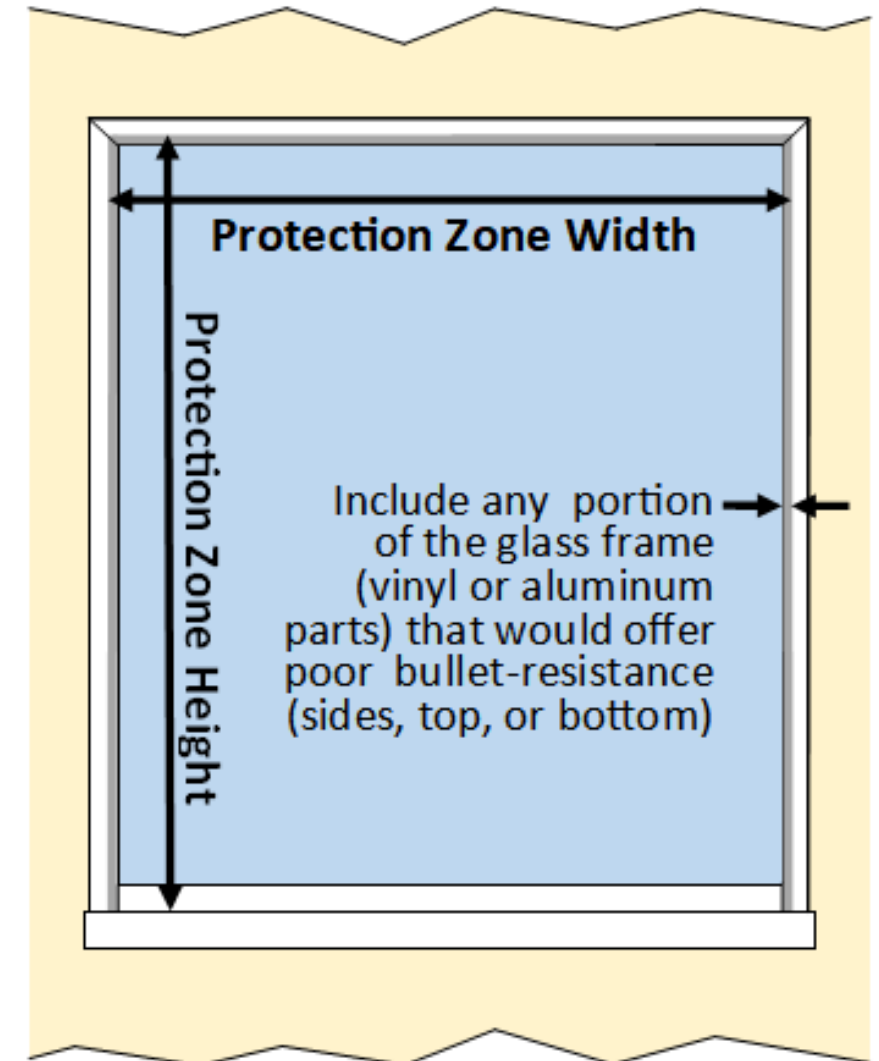

Door Measurements

Measure the opening width and height

- The door Protection Zone is defined as the minimum area that has no ability to stop bullets.
- This is usually:
 - The door slab itself
 - And the slight gap between the slab and the frame
- Measuring from the inside of the frame, edge to edge and inside of frame top to the door threshold is usually all that is required

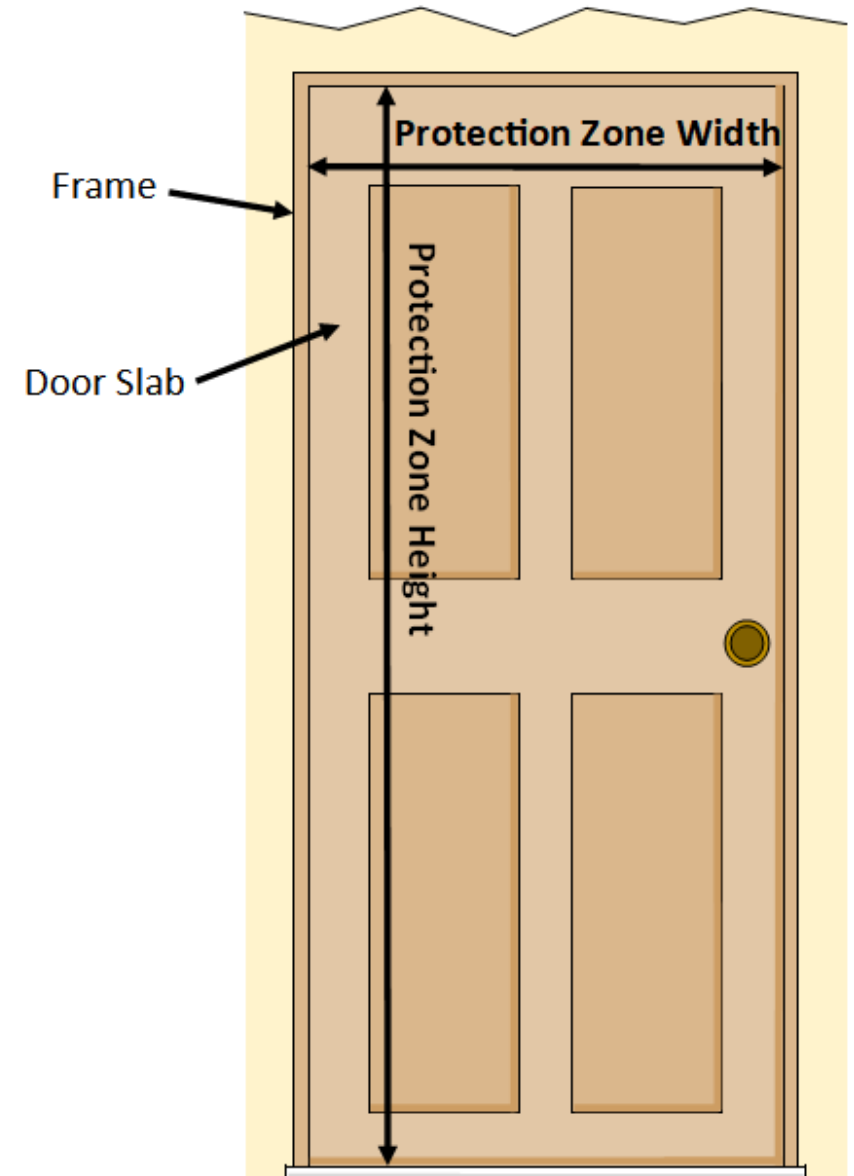

Measurements: Additional Protection Overhang

- Discuss with the customer that a roll-up/down covering for a door or window should be oversized and 3-4 inches bigger in each direction.
 - This is to stop bullets that are fired at the edge of the window/door at an angle or very near the edge. An overhang of 3-4" will stop bullets fired at about a 45° angle towards the edge.
 - Doors are an exception in the direction of the floor only
 - If this is not acceptable, determine an oversize limit that will meet their satisfaction.

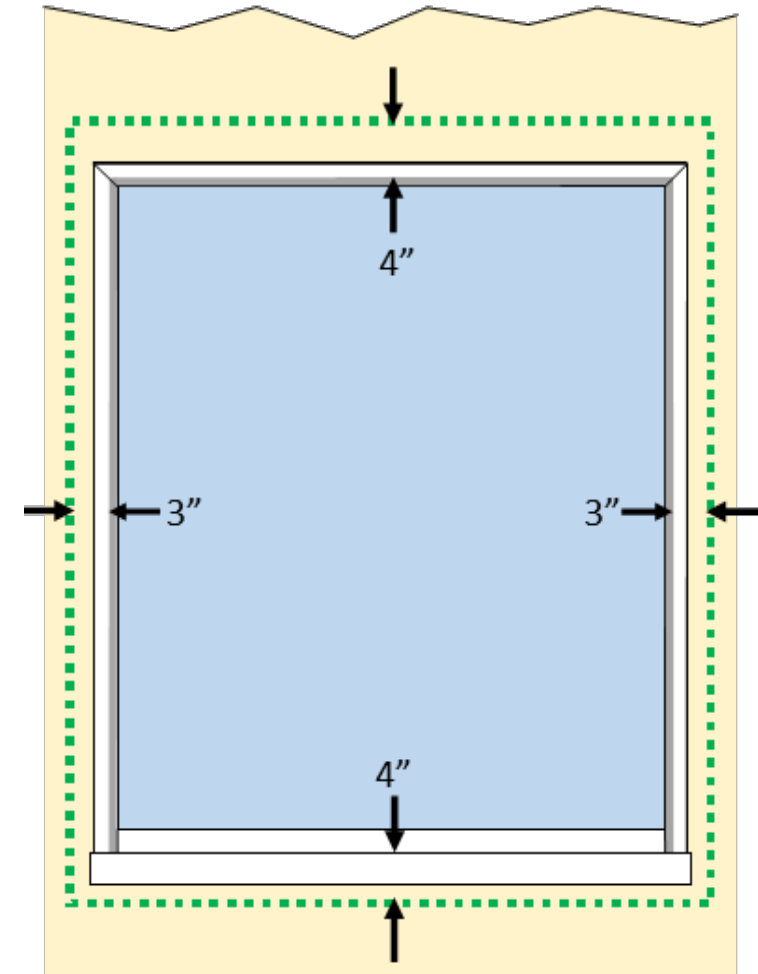

Measurements: Clearance for BBP Hardware

3. Determine if there is at least 12" of clearance between the top of the door/window "opening" and the ceiling or any object that would be in the way of mounting the roll fixture.
4. Is there at least 8" of clearance below the bottom edge of the "opening" for any Hem Bar restraints?
5. Is there at least 3" clearance on each side?
6. Will the Hem Bar clear the window sill?

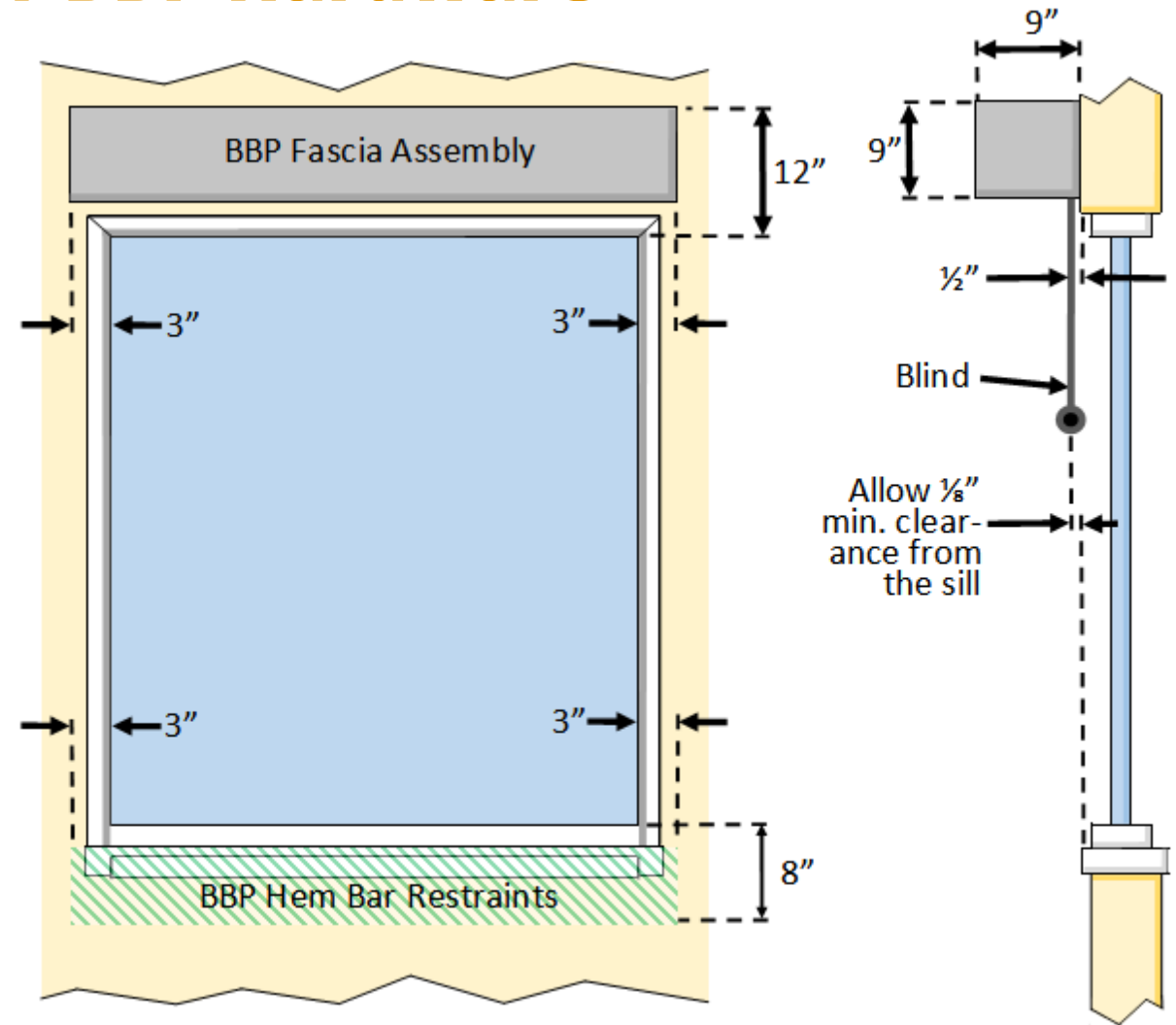

Measurements: Fund the King Stud and Header

2. Using a stud finder, locate the “King Stud” at BOTH sides of the window/door frame. This is a wood or metal stud that runs from the floor to the ceiling and to which the door/window frame is attached.
 - Ideally, all of the wall-mounted brackets should be attached to this king stud.
 - Determine the middle of the king stud
 - Measure the distance from the middle of the kind stud to the outside of the door/window “protection” zone, measured in step 1., measure both sides.

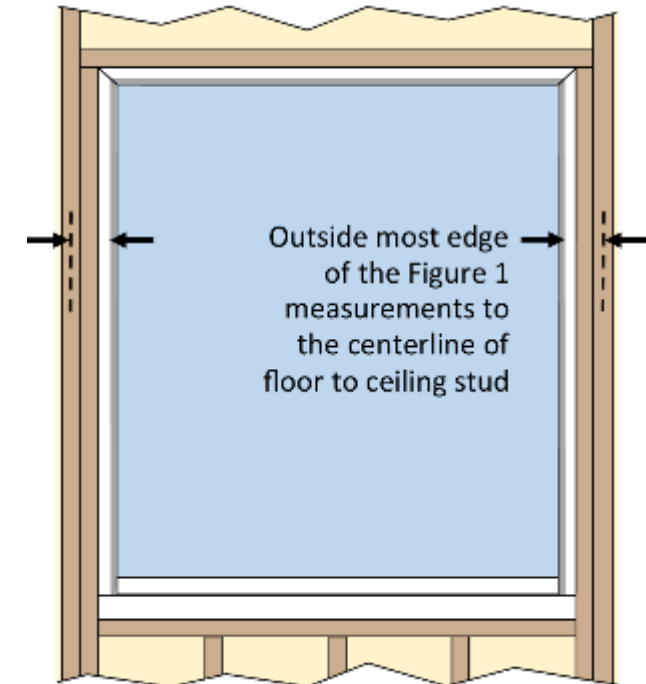

King Stud and Header Variations

- Header that spans the entire top
- Double King Stud
 - Moves King Stud further away from the frame
- Non-Standard Spacing
 - Moves King Stud further away from the frame
- Header is set back
 - Standard stud finder will not indicate that the framing is sub-flush to the sheetrock
- If you are unable to determine the King Stud locations with a stud finder, drill small pilot holes to determine where the studs are.



Measurements: Window Mullions

- If there is a mullion (strip of wall or window frame between the windowpanes), measure the width.
 - This will need to be covered with excess overhanging material or a piece of bullet-resistant fiberglass.

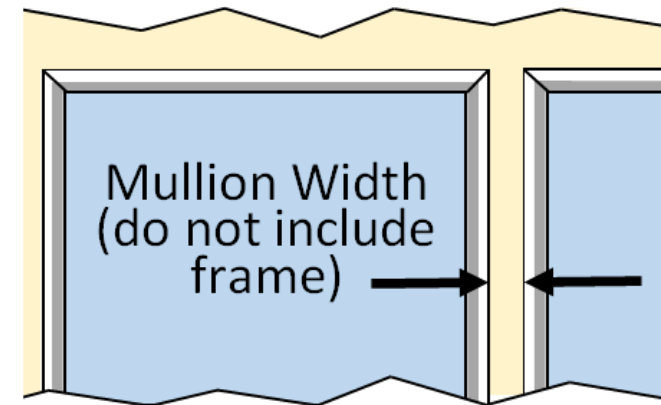

Measurements: Nearby Obstacles/Issues

- Photograph the entire window/door and include it with the submitted measurements.
- Take close-up images of unique obstacles or possible clearance issues.

Low ceiling
clearance

Nearby wall



Drop down
ceiling

Barrier Measurements

- All custom, all different
- Photograph the environment
- Measure the basic shape of desired coverage
- Look for obstacles to work around
 - Measure size and position relative to a major feature
- BBP will make its best effort to be ready for an ad-hoc video conference to consult



Typical Installation Examples

BBP Order Forms

- HARD** requirement to use the BBP measurement forms:

- Window Shades
- Door Covers
- Fixed Door Shields
- Curtains

- No orders accepted without a measurement form

Roll-Up Window Shades and Door Shields

1. Fill out sections 1-10 completely (inches assumed, if metric, indicate as such)
 2. Scan and return to sales@ballisticbarrier.com
 3. For existing construction, you must include a photo of each door, including 12 inches in each direction around it.
 For any new fabric or construction option not listed here, contact sales@ballisticbarrier.com directly with your request.

Measurements

Door (shade only)	20x28	20x30	20x34	20x36	20x38	Custom
Window/Curtain Door width						
Window/Curtain Door height	See Figure 1					
Edge of door/window frame to floor to rolling length (shut)	Left		Right			See Figure 2
Stool material	Fiberglass	Wood	Steel	Concrete		
Door/window trim width	If width varies, describe trim width on all four sides in section 10					
Size limitations	Maximum window shade roll length is 130' (Other the width or the length can exceed 130' but not both)					

Check Size by Detachable (See Figure 3)

Remove the attachment frame At least 12" clearance If no, then please photograph the attachment and provide the distance to the left and right of the frame At least 12" clearance, 6x2' 00" Below the frame (windows only) At least 2" clearance

Threshold Level (select one)

UL 752 Level 1 Up to 44 Magnon protection
 UL 752 Level 2 Up to 357 Magnon and 5mm protection

Mounting (select one)

Wall mount
 Ceiling mount

Color (select one)

Manual (left side) Full cover (right side) Manual (right side) Must be >10 sq ft
 Manual (left side) Full cover (right side) Manual (right side) Must be >10 sq ft

Roller (select one)

None
 Custom (select one) Color: Height, Winter, Snow (see below)
 Fully covered Style: Choose to match cover fabric or custom

Item for attention (select one)

None Recommended overall size >12 sq ft
 Looking for bar Windows only
 Code pulled Windows or doors

Cover Fabric Type (select one)

Standard polyurethane
 Custom fabric (select one)

Cover Fabric Color (select one)

Standard colors (select one)

Special Considerations (Name blank if none)

Curtains

1. Fill out sections 1-10 completely (inches assumed, if metric, indicate as such)
 2. Scan and return to sales@ballisticbarrier.com
 3. For existing construction, you must include a photo of each window/door, including 12 inches in each direction around it.
 For any new fabric or construction option not listed here, contact sales@ballisticbarrier.com directly with your request.

Measurements

Window width (inches)	See Figure 1
Window height (inches) <td>See Figure 2</td>	See Figure 2
Window, edge of frame to stud (center)	Left Right See Figure 2
Window trim width	If width varies, describe trim width on all four sides in section 8

Size Limitations Allow the width or the height to exceed 130' but not both

Windowing Style (select one)

Yes No
 Above the window frame At least 12" clearance If no, then please photograph the window and provide the distance to the left and right of the frame At least 12" clearance, 6x2' 00" Below the window frame At least 2" clearance To the left and right of the frame At least 12" clearance, 6x2' 00"

Mounting (select one)

Up to 44 Magnon protection
 Up to 357 Magnon and 5mm protection

Material (select one)

Standard, Water proofing plug
 Custom (select one) Request items 2, 3, 4, 5, 6

Color (select one)

Standard colors (select one)

Special Considerations (Name blank if none)

Fixed Panel Door Shields

1. Fill out sections 1-10 completely (inches assumed, if metric, indicate as such)
 2. Scan and return to sales@ballisticbarrier.com
 3. For existing construction, you must include a photo of each door, including 12 inches in each direction around it.
 For any new fabric or construction option not listed here, contact sales@ballisticbarrier.com directly with your request.

Measurements

Door width	20x28	20x30	20x34	20x36	20x38	Custom
Door height						
Door clear	Include above or under and/or of actual obstacle, with dimensions showing to the left and/or right of the door and all sides of the door					
Door edge	Left Right					
Door panel	Water	Wood	Steel	Concrete		

Threshold Level (select one)

UL 752 Level 1 Up to 44 Magnon protection
 UL 752 Level 2 Up to 357 Magnon and 5mm protection

Window in Door (select one)

No window
 Window (see Figure 1) Width: Height: To door top: To door edge (R)
 Window cover addition (see Figure 2) Create a matching hole in the header: To door edge (R)
 Flip up cover: Sliding frame

Door Break/Frame Rein (select all that apply)

Full bar: Header and mullion needed, if not suitable, BBP will provide measurement guidance
 Door head (or vent): Backset: 2 1/4" 2 3/4" (See Figure 1)
 Head bar: Distance of head bar from center of door
 Head bar: Distance from center of door to center of head bar

Door Label (select one)

Left side of door
 Right side of door

Door Main Material (select one)

Custom cover: Select one (select one) If no, then please photograph the obstacle and provide the distance to it from the nearest edge in inches below
 Follow cover wood: Drilling through (select one) Hole size: Hole depth: Hole width:
 Hollow core metal: Hole width:
 Fiberglass: Door shield will be free to move as door opens and closes.
 None required: Flow of water will require the bottom of the header, being it in place

Cover Fabric Type (select one)

Standard polyurethane
 Custom fabric (select one)

Cover Fabric Color (select one)

Standard colors (select one)

Special Considerations (Name blank if none)

Installation: Roll-Up Window or Door Cover

Three Key Elements:

1. Wall Bracket

- Mounts above the window or door frame
- Equal distance from the centerline of the frame
- MUST mount to any stud of the frame
- Use the prescribed screw or masonry anchors

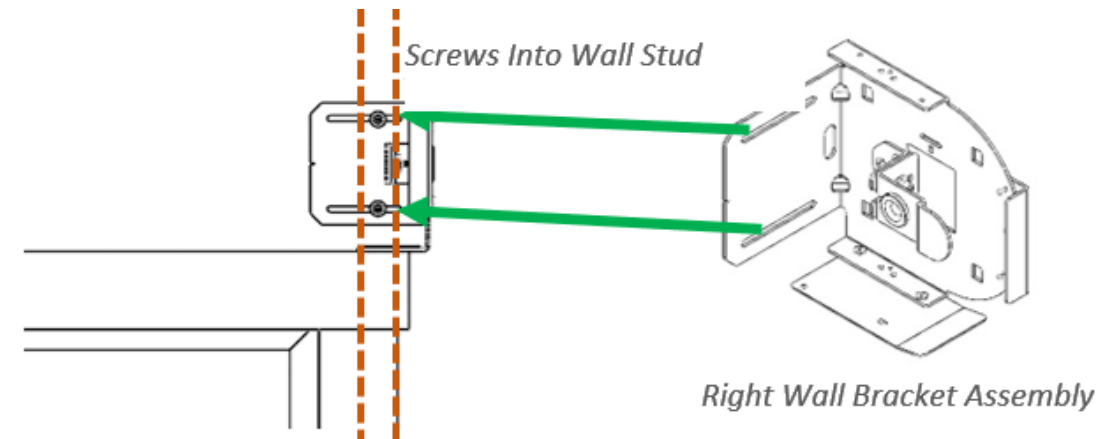
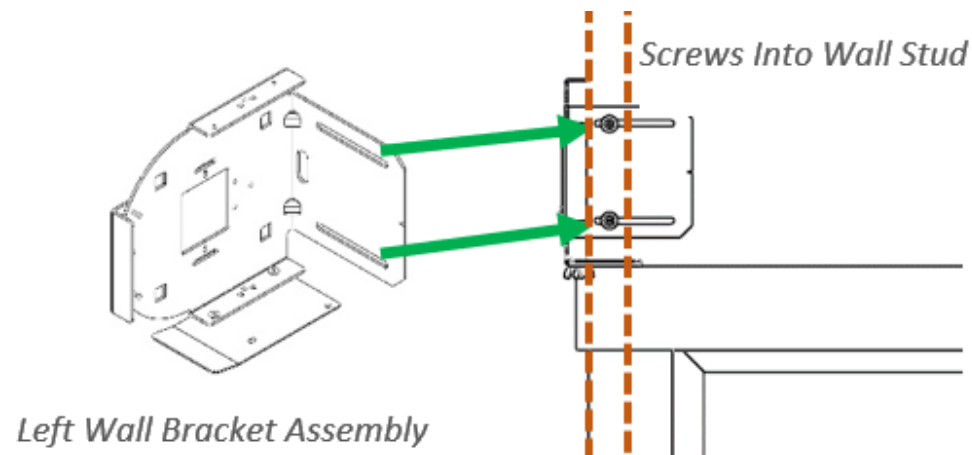
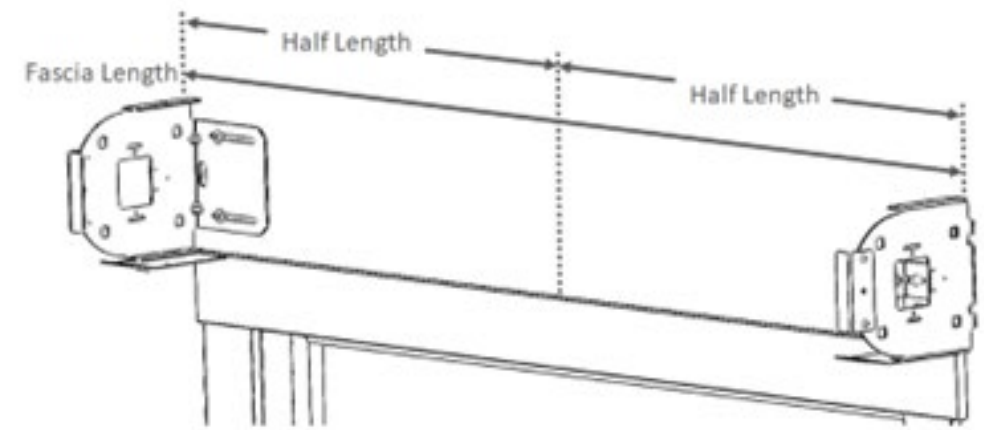

Installation: Typical Window or Door

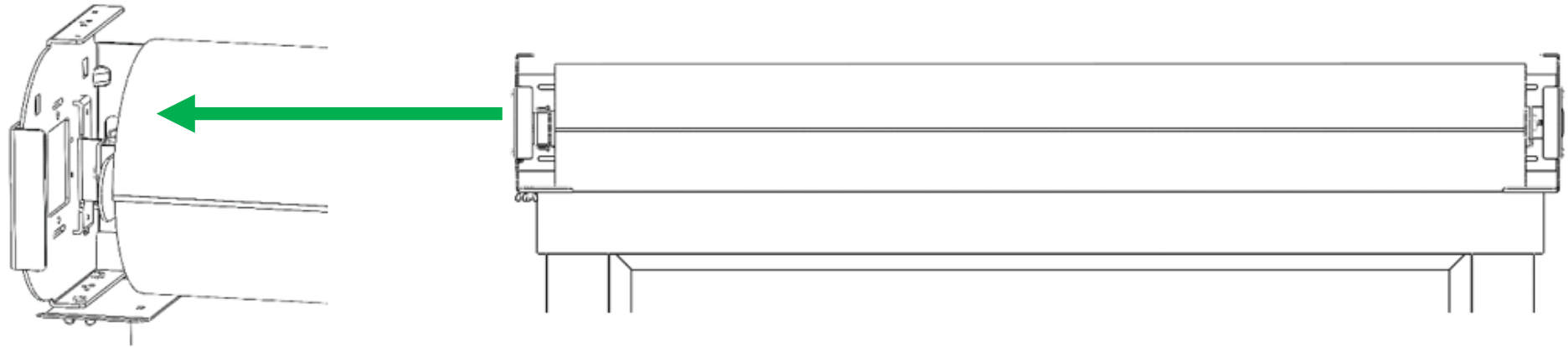

2. The Roll Good

- Slides in between the two wall brackets
- Power up the motor (wall plug or direct wire), synch the remote
- Add any fascia or housing materials

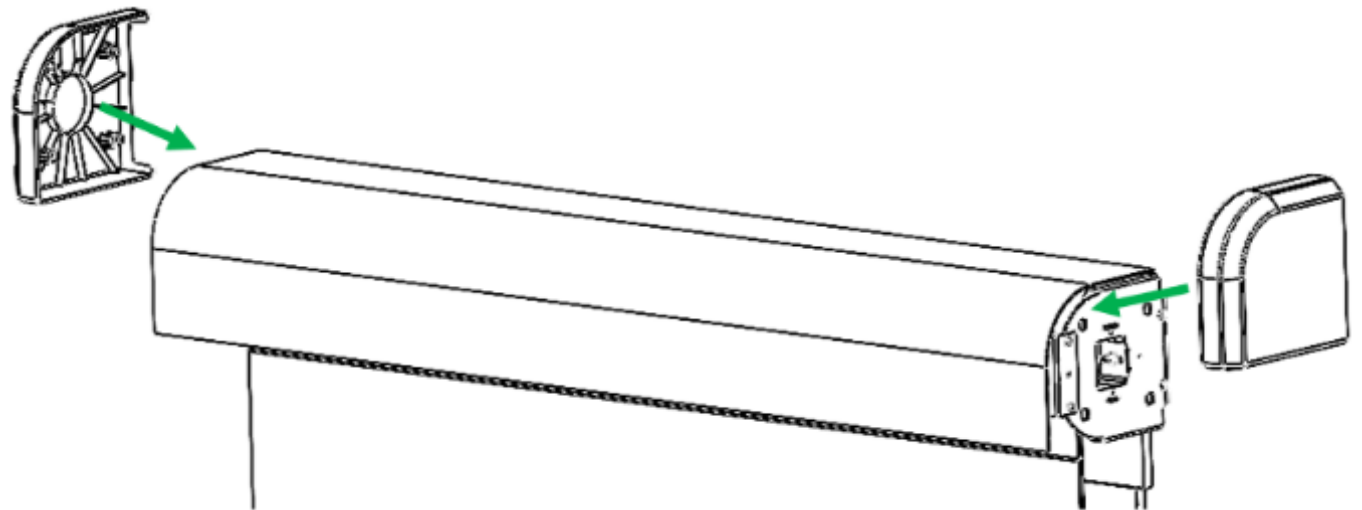

Installation: Typical Window or Door

3. The "Hem Bar Retainer"

- Hem Bar Locks mount below the window
- Cable Guides mount at the bottom of the door
- Extend the Roll Good to determine the mounting position
- MUST mount screws to a wall stud

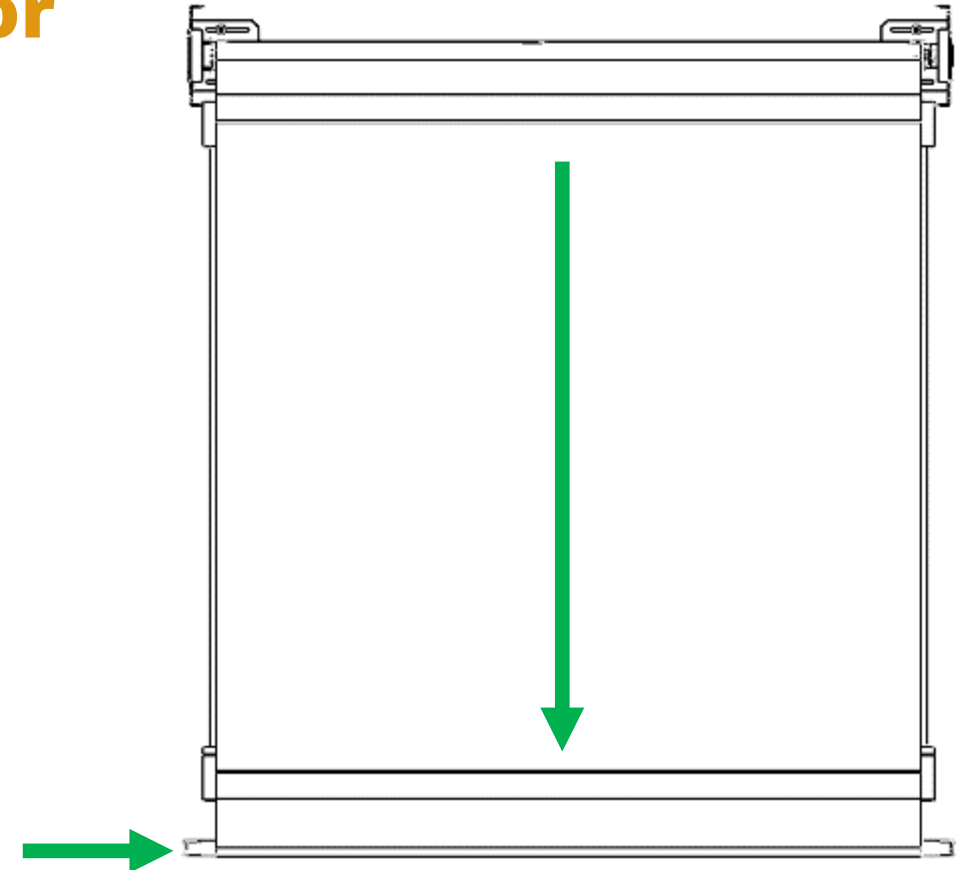
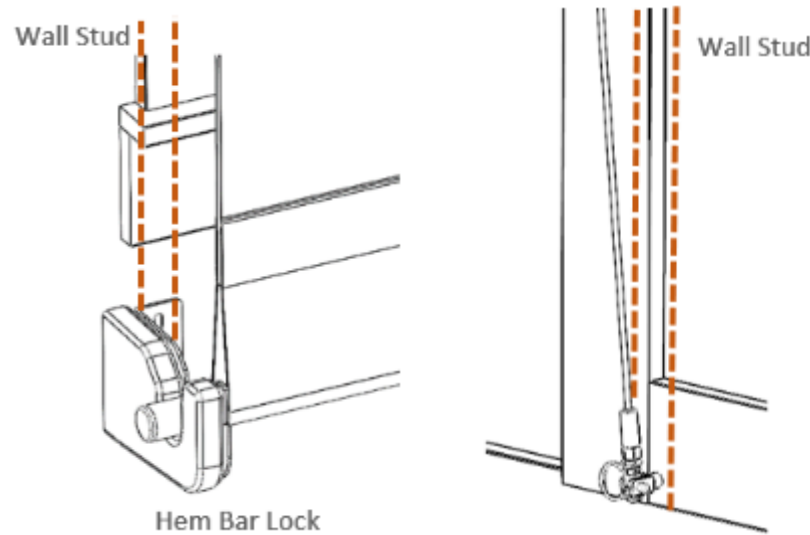

Installation: Door Panel

- Mounts directly to the door, opposite side from the direction of gunfire
- Single row of mounting points at the top of the door
 - Below door closer, if applicable
- Kevlar stops short of the kick plate
 - ADA requires the contact friction to be unchanged (for wheelchair contact)
 - A fiberglass backer can be installed behind the kickplate if ground-level protection is a concern
- The bottom can be secured from moving freely with industrial Velcro or another row of elastomer and mounting screws
- **One Caveat:** Kevlar does not drill well. It can be pierced, and screws run through the piercing, or we can cut holes $>1"$. So mounting holes that are needed between $\frac{1}{4}$ and $1"$ need discussion.

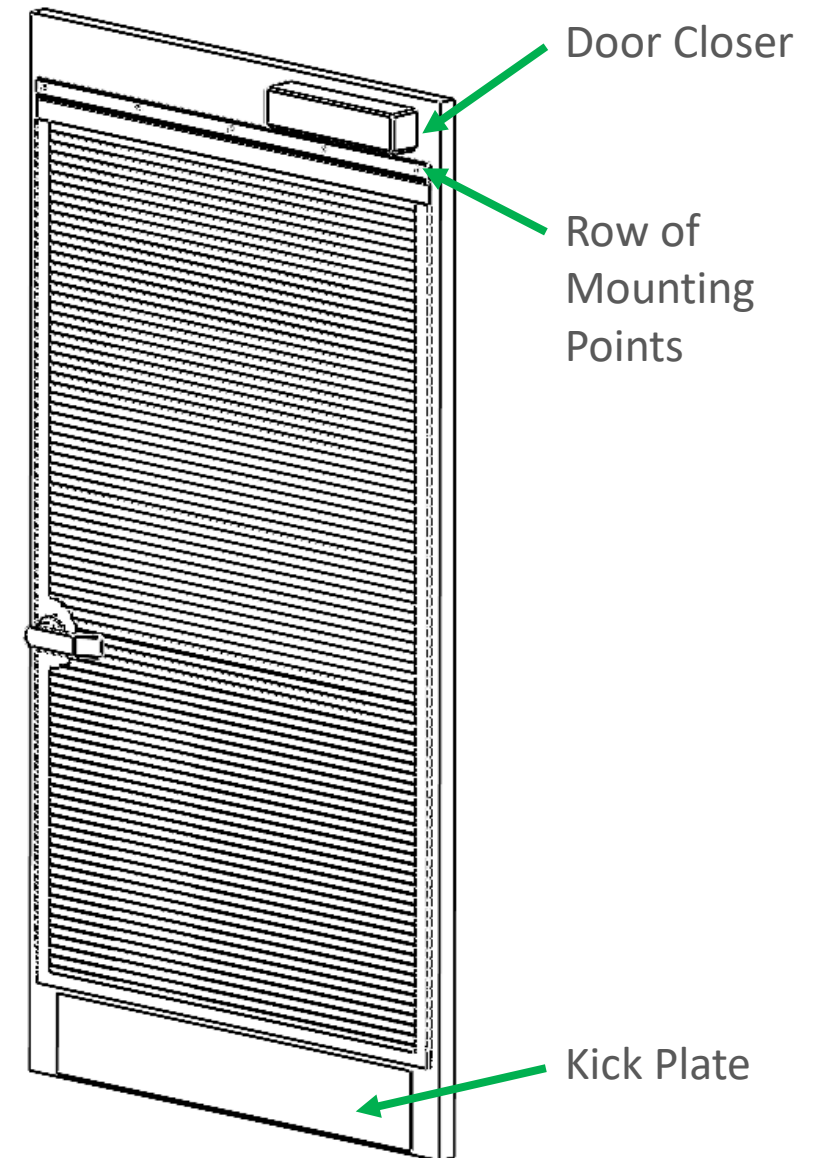

Installation: Door Panel

1. The door is removed from the hinges, lay on the floor
2. Remove the doorknob
3. Lay out the Kevlar panel
4. Remount the doorknob over the top of the Kevlar
5. Mount the screws/bolts at the top of the Kevlar panel (directly into the door)



Anatomy of the sales process

1. Budgetary pricing.
 1. Rough dimensions needed
 2. Shades and curtains – motorized or manual
 3. Pictures really help to address obstructions and potential fire code violations. Can be taken by client.
 4. On site measuring – feel free to charge for function with a ‘buy rebate’ option. See detail under “2”
2. Firm pricing.
 1. Measurement form needs to be completed
 2. On site measuring is highly recommended (measuring cost may be refunded at time of order.)
 - \$150 for 1-3 windows
 - \$500 for 3-30 windows
 - \$750 for 30+ or multiple buildings
 - Mileage is always an adder at gov rate.
 3. Installer identified.
 - Alarm company coordination required?
 - Permitting?
3. Purchase Order.
 1. Terms – Invoice or order confirmation
 2. Construction / Design / Pricing of Product – Price, Quantity and size of each shade/door/gate accuracy to quote.
 3. Shipping method & location – Lift gate required? Palletized or roll good.
 4. Timeline – General estimate of lead-time
 5. Order review - Prints, installation manual, review of details included in proposal
 6. Manufacturing